

ITEM	DESCRIPTION	DETAIL	MATERIAL	Q'TY
1	CAP CASTING	SD636	FC 200	1
2	BASE CASTING	SD636	FC 200	1
3	HEX HEAD BOLT	M30×3.5P×190LG	AISI-1010	4
4	LOCK WASHER	M30	AISI-1045	4
5	DOWEL PIN	φ1/2"×45LG	AISI-1010	2
6	EYE BOLT	W5/8"	AISI-1010	2
7	GREASE NIPPLE	PT 1/4	AISI-1010	1
8	METAL PLUG	PT 1/4	AISI-1010	2

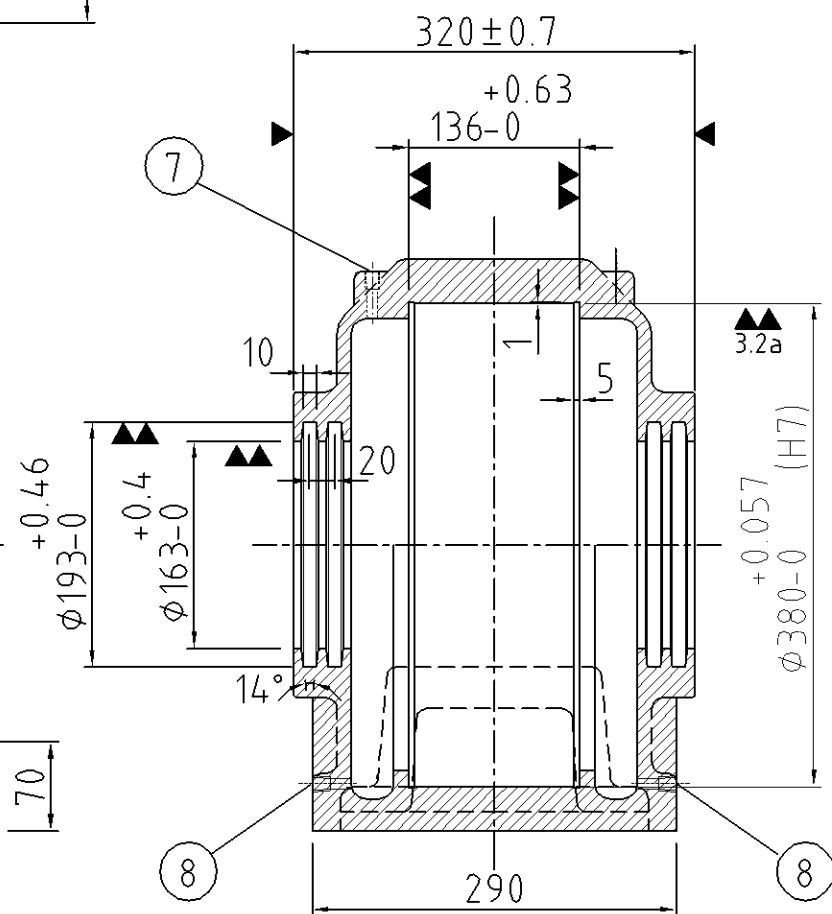
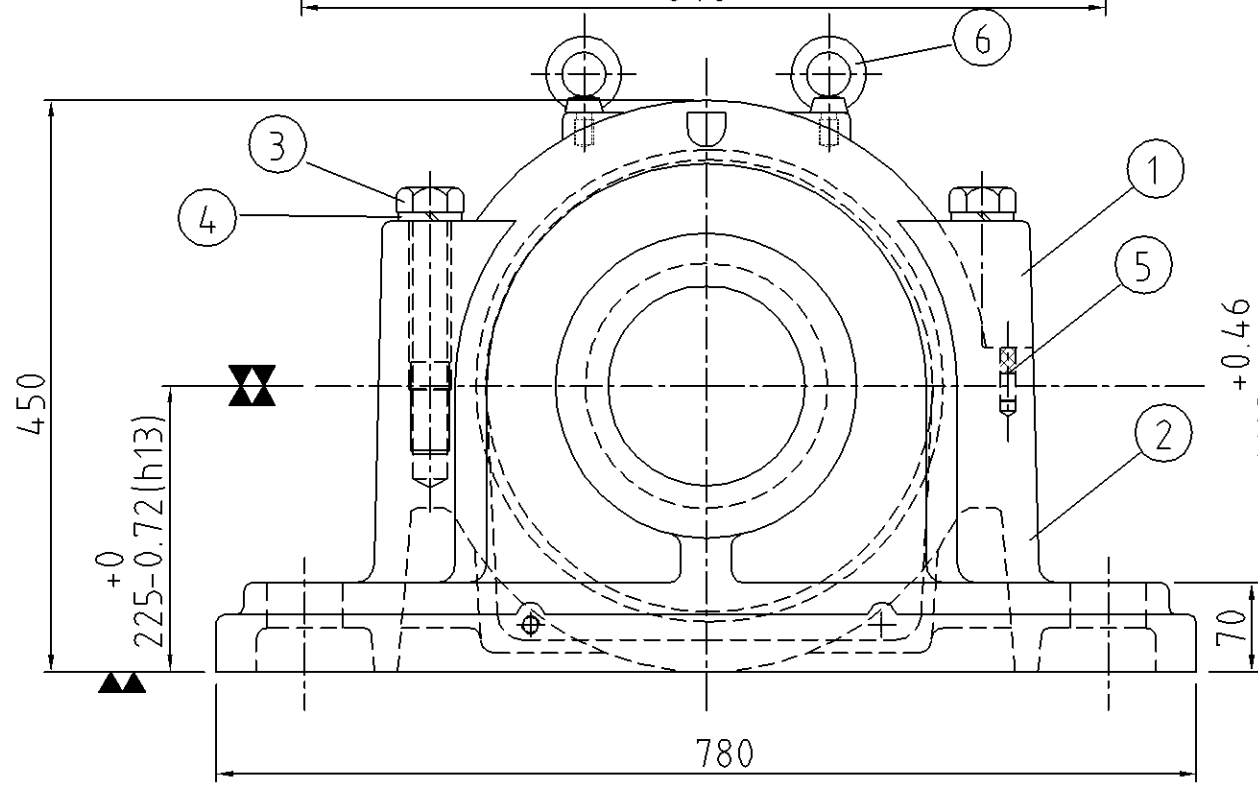

FAIR FRIEND ENT. GROUP.

REV.	MARK	CAREER	NAME	DATE

敬告 RESTRICTED
 此圖乃友迦工業(股)公司財產,未經本公司正式授權,不得私自影印或將內容透漏與第三者。
 THIS DRAWING IS PROPERTY OF FAIRSKQ (TAIWAN) CO., LTD. AND IS TRANSMITTED TO YOU AS A CONFIDENTIAL DISCLOSURE. IT SHALL NOT BE COPIED OR IT'S CONTENTS REVEALED TO OUTSIDE PARTIES WITHOUT WRITTEN CONSENT OF FAIRSKQ (TAIWAN) CO., LTD.

NAME		DATE		FAIRSKQ (TAIWAN) CO., LTD.	DRAWING NAME	DRAWING NO	EDITION
DRAWN	C.M.T	2010/09/21					
CHECKED	K.Y.S	2010/09/21					
SCALE		Issue					