

| ITEM | DESCRIPTION | DETAIL | MATERIAL | Q'TY |
|------|---------------|---------------|-----------|------|
| 1 | CAP CASTING | SNZ218 | FC200 | 1 |
| 2 | BASE CASTING | SNZ218 | FC200 | 1 |
| 3 | HEX.HEAD BOLT | M16×2.0P×80LG | AISI-1010 | 2 |
| 4 | LOCK WASHER | M16 | AISI-1045 | 2 |
| 5 | DOWEL PIN | φ5×12LG | AISI-1045 | 2 |
| 6 | GREASE NIPPLE | PT 1/8 | AISI-1010 | 1 |
| 7 | METAL PLUG | PT 1/8 | AISI-1010 | 1 |

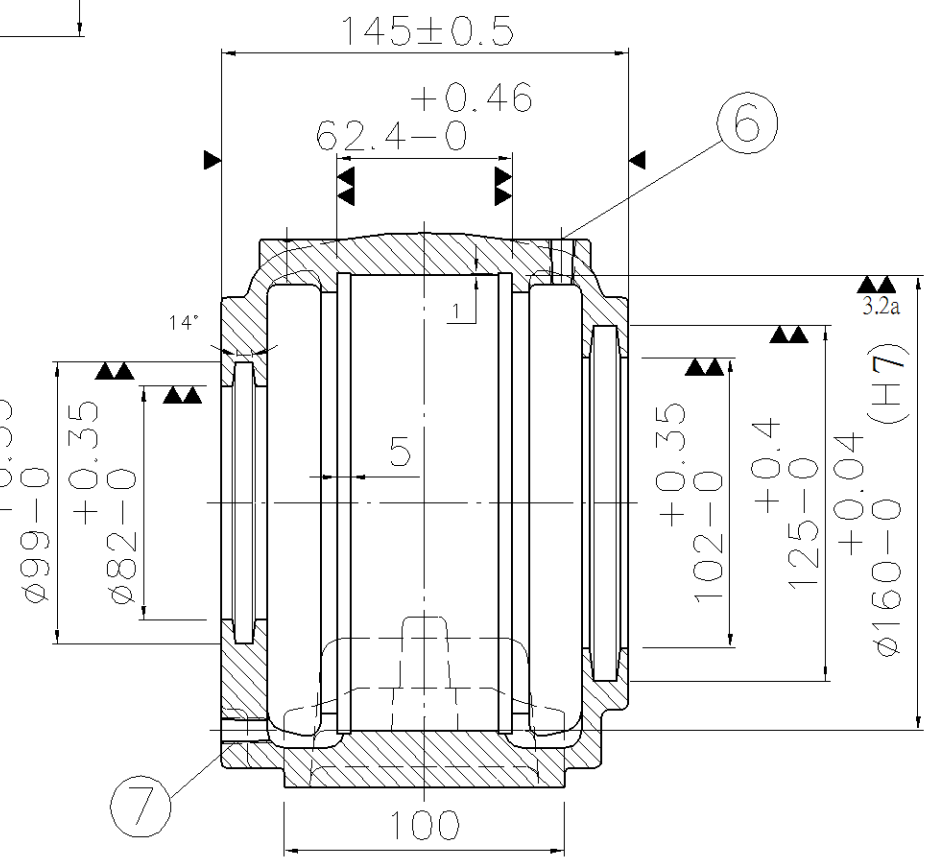
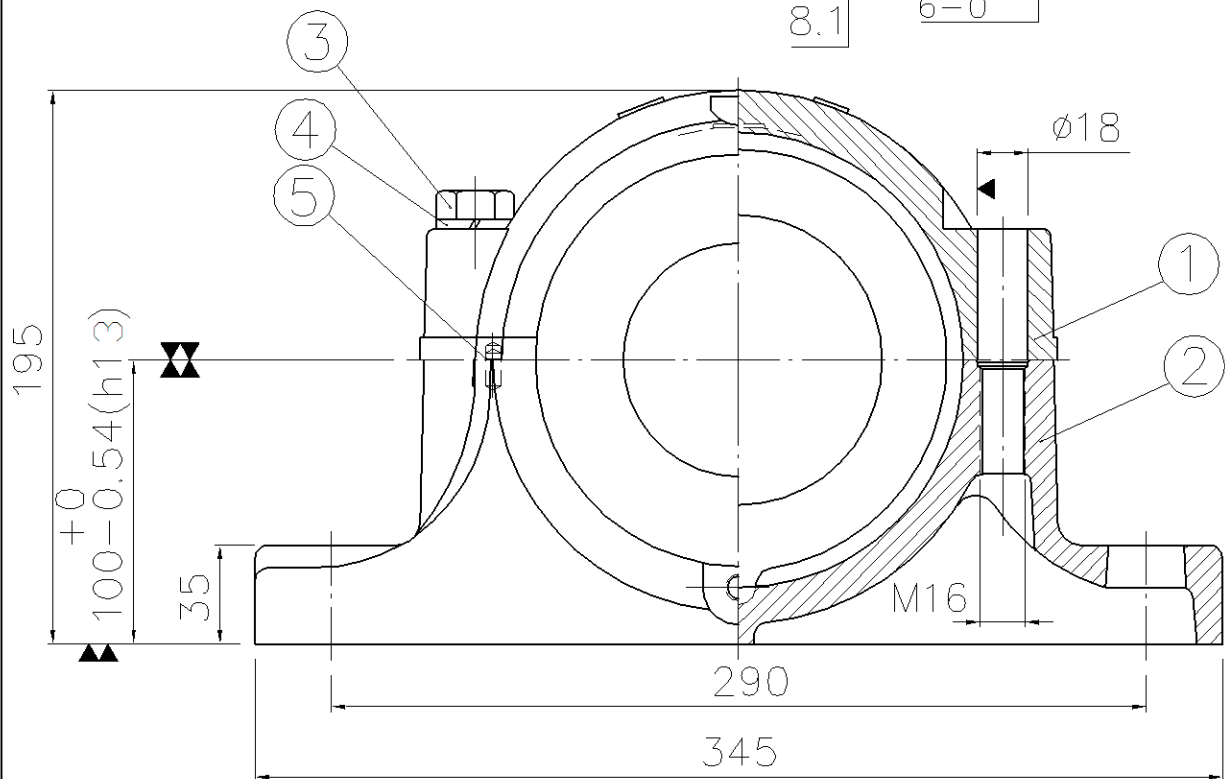

FAIR FRIEND ENT. GROUP.

| | | | | | | | | |
|---------|--|-------|--|--------------|--|--|--|----------|
| DRAWN | | NAME | | DATE | | FSQ FAIRSKQ (TAIWAN) CO., LTD. | | |
| CHECKED | | K.Y.S | | 2010/11/22 | | | | |
| SCALE | | Issue | | DRAWING NAME | | DRAWING NO | | EDITION |
| | | | | | | SNZ218 | | PB37218D |
| | | | | | | | | 00 |

敬告 RESTRICTED
 此圖乃友迦工業(股)公司財產,未經本公司正式授權,不得私自影印或將內容透漏與第三者。
 THIS DRAWING IS PROPERTY OF FAIRSKQ (TAIWAN) CO., LTD. AND IS TRANSMITTED TO YOU AS A CONFIDENTIAL DISCLOSURE. IT SHALL NOT BE COPIED OR IT'S CONTENTS REVEALED TO OUTSIDE PARTIES WITHOUT WRITTEN CONSENT OF FAIRSKQ (TAIWAN) CO., LTD.

| REV. | MARK | CAREER | NAME | DATE |
|------|------|--------|------|------|
| | | | | |