

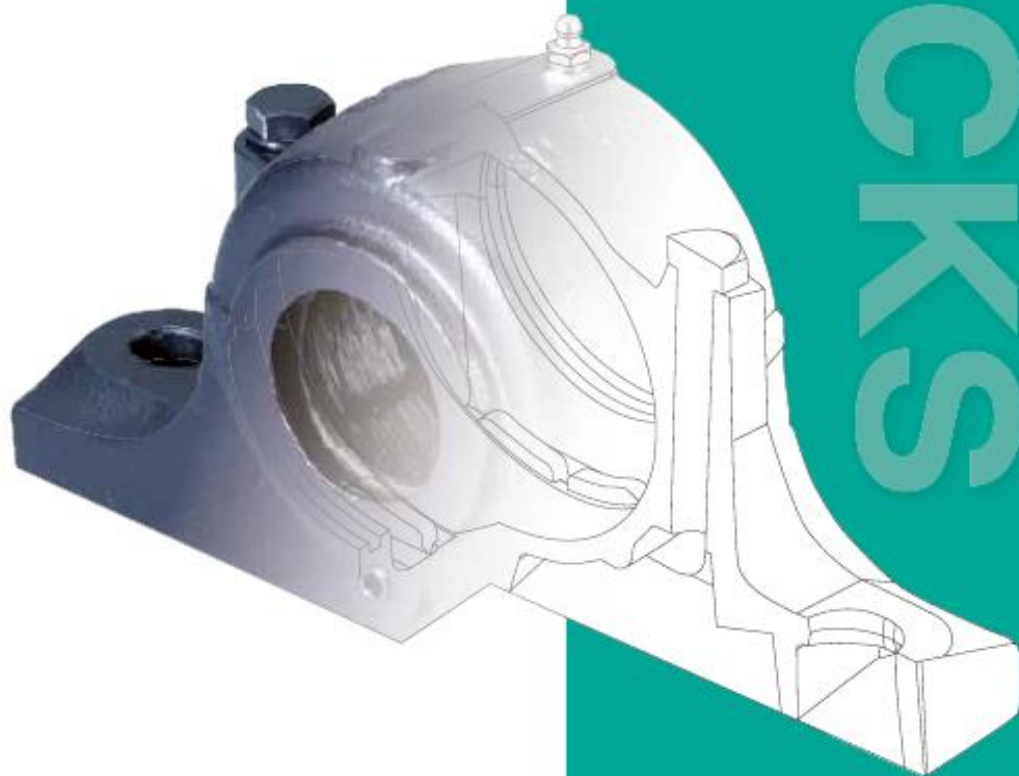

We Bear The Rolling World



PLUMMIER
BLOCKS

令和5年5月

プランマ ブロック

価格表

FAIRSKQ (TAIWAN) Co.,Ltd.



〈会社概要〉

会社名：友迦工業股份有限公司

設立：1978年

資本金：3.4 million USD

本社：No.186 YUNG CHI ROAD, TAIPEI 110, TAIWAN, R.O.C

URL：http://fsq.com.tw

主な取引先：旭精工株式会社ほか国内有力ベアリングメーカー2社

スウェーデン 有力ベアリングメーカー

ドイツ 有力ベアリングメーカー



在庫型番

SN505~SN532	SNZ205~SNZ232	SD534~SD560
SN605~SN632	SNZ305~SNZ332	SD634~SD656
SN205~SN232	SN3024~SN3052	SD3034~SD3068
SN305~SN332	SN3122~SN3138	SD3134~SD3160

ハウジングの
呼び番号

Housing Designation

規格 /
許容回転数

Standard & Tolerances

カタログに記載のスプリット軸受台ベアリングハウジングは鋳造品であり、ISO/R113-1994規格に基づいて製造されています (B.S.1642:1969規格、JIS B1551-1968規格)。以下の表は、原材料の標準化状況ならびに相対的な加工時許容回転数 (ハウジングおよび付属品を含む) を表したものです。

1. 原材料

A. ハウジング

原材料	ISOコード	米国規格コード	引張強度 kgf/mm ²	降伏強度 kgf/mm ²	伸び
鋳鉄	グレード200 (FC200)	ASTM A48 グレード 30	20	—	—
ダクタイル鋳鉄 (S.G.)	グレード450-10 (FCD450)	ASTM A536 グレード 65-45-12	45	30	10%
鋳鋼	グレード230-450 (SC450)	ASTM A27 グレード 65-35	46	23	19%

※ステンレス鋳物材も製作できます。

B. 付属品

名称	部品番号	原材料
フェルト	FS	毛80%、レーヨン20%、密度0.25g/cm ³
位置決めリング	SR	FC200
六角ボルト	M	軟鋼 AISI 1010(SS41) / グレード8.8
ZF型シール	ZF	ニトリルゴム
TC型シール	OSM	ニトリルゴム
U-LOKシール	U-500	ニトリルゴム
TSNGシール	TSNG500	ニトリルゴム
Vリングシール	TSNA500	ニトリルゴム、軟鋼板
ラビリンスシール	TS/LER	鋳鉄 / アルミ
タコナイト運搬装置	TAC/TER/TACK	鋳鉄
エンドカバー	EPS	FC200
エンドプレート	P	軟鋼板
エンドカバー	TSA	鋳鉄
エンドプラグ	EPR	ニトリルゴム、軟鋼板
アイボルト	W/M	軟鋼 AISI 1010

※注意: このカタログに記載の事項は予告なく変更することがあります。

規格 /
許容回転数

Standard & Tolerances

2. 機械許容回転数

A. ハウジング内径

(μm)

内径 mm	G7	H7	H8	J7
10 - 18	+24 +6	+18 -0	+27 -0	+10 -8
18 - 30	+28 +7	+21 -0	+33 -0	+12 -9
30 - 50	+34 +9	+25 -0	+39 -0	+14 -11
50 - 80	+40 +10	+30 -0	+46 -0	+18 -12
80 - 120	+47 +12	+35 -0	+54 -0	+22 -13
120 - 180	+54 +14	+40 -0	+63 -0	+26 -14
180 - 250	+61 +15	+46 -0	+72 -0	+30 -16
250 - 315	+69 +17	+52 -0	+81 -0	+36 -16
315 - 400	+75 +18	+57 -0	+89 -0	+39 -18
400 - 500	+83 +20	+63 -0	+97 -0	+43 -20
500 - 620	+92 +23	+70 -0	+110 -0	+46 -23

B. ハウジング内径以外

(μm)

寸法 mm	H10	H11	H12	H13	h13
10 - 18	+70 -0	+110 -0	+180 -0	+270 -0	+0 -270
18 - 30	+84 -0	+130 -0	+210 -0	+330 -0	+0 -330
30 - 50	+100 -0	+160 -0	+250 -0	+390 -0	+0 -390
50 - 80	+120 -0	+190 -0	+300 -0	+460 -0	+0 -460
80 - 120	+140 -0	+220 -0	+350 -0	+540 -0	+0 -540
120 - 180	+160 -0	+250 -0	+400 -0	+630 -0	+0 -630
180 - 250	+185 -0	+290 -0	+460 -0	+720 -0	+0 -720
250 - 315	+210 -0	+320 -0	+520 -0	+810 -0	+0 -810
315 - 400	+230 -0	+360 -0	+570 -0	+890 -0	+0 -890

C. ベアリングハウジング許容回転数の選定

条件		例	ISOによる 許容回転数番号
方向不定荷重	普通荷重、軽荷重、 望ましい外輪のアキシャル変位	電気モーター、ポンプ、 クランクシャフトメインベアリング	J7
	衝撃荷重、一時完了除荷	鉄道車両の軸箱	
外輪固定荷重	全荷重	ベアリング利用全般、 鉄道車両の軸箱	H7
	普通荷重、軽荷重、 単純作業時の荷重	ラインシャフトの軸材	H8
	軸を通した伝熱	ドライヤーシリンダー	G7

SNKハウジング

SNK Housings

SNA/SNU/SNH/SNN/SNV/SNLと互換します。

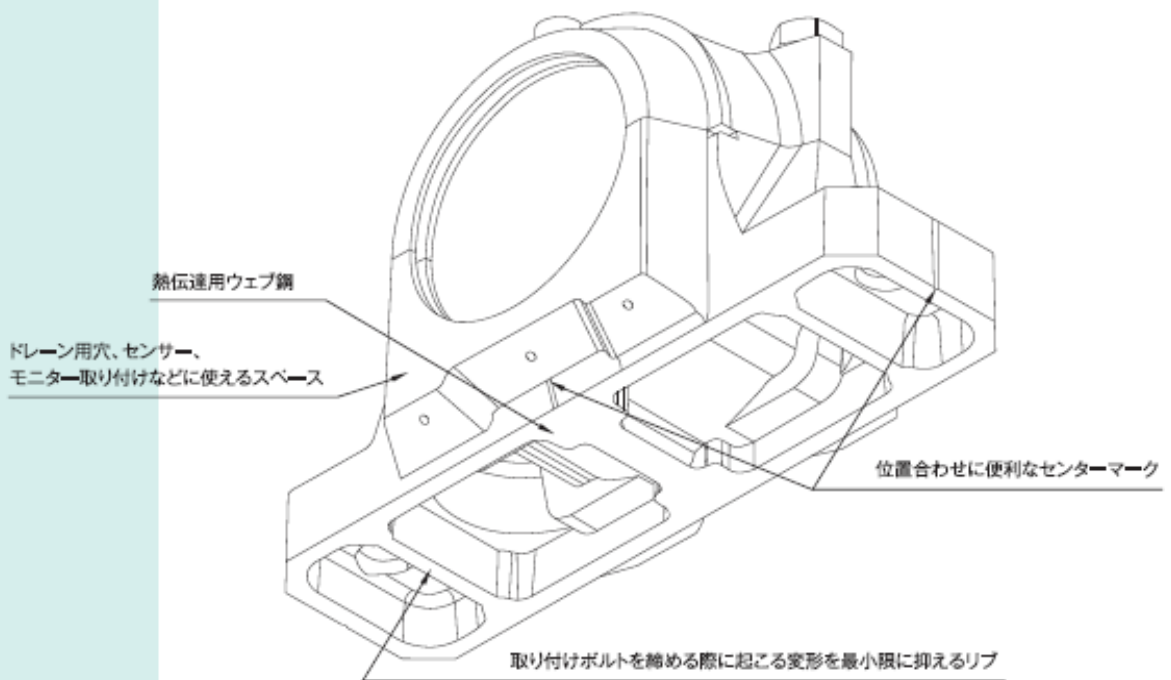
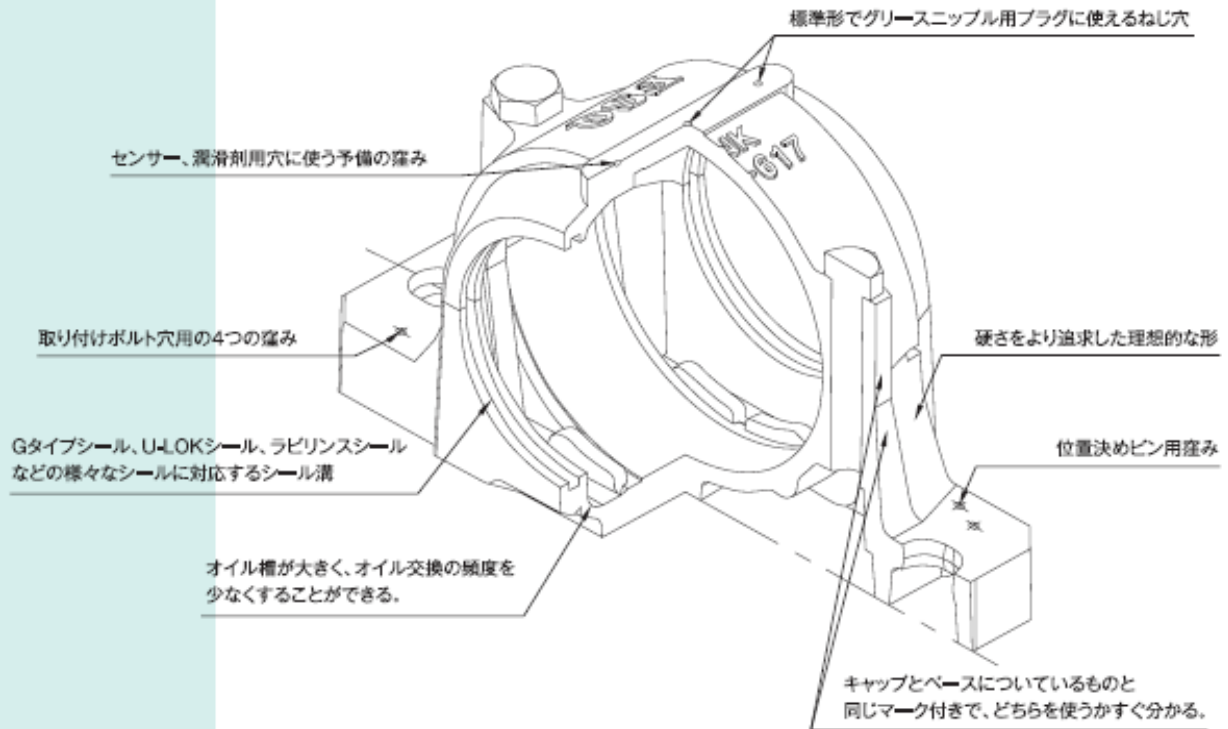

SN500型

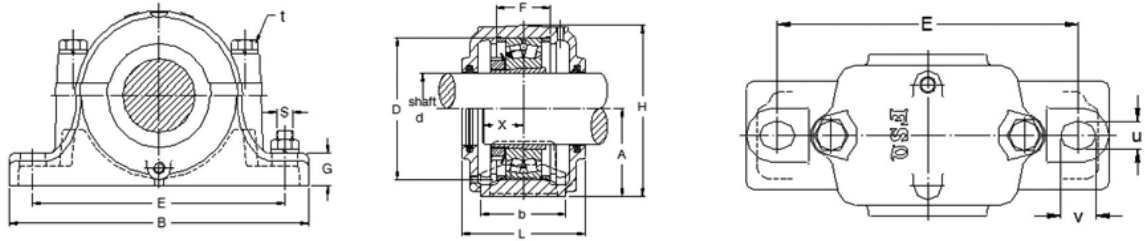

型番	価格(円)	d	D	B	b	G	F	A	L	H	E	X	U	V	S	重量(kg)
SN505	8,110	20	52	165	46	22	25	40	67	75	130	22	15	20	M12	1.50
506	8,440	25	62	185	52	22	30	50	77	90	150	22	15	20	M12	1.74
507	8,650	30	72	185	52	22	33	50	82	95	150	24	15	20	M12	1.90
508	9,710	35	80	205	60	25	33	60	85	110	170	26	15	20	M12	2.63
SN509	10,140	40	85	205	60	25	31	60	85	112	170	28	15	20	M12	2.64
510	10,660	45	90	205	60	25	33	60	90	115	170	28	15	20	M12	2.80
511	13,340	50	100	255	70	25	33	70	95	130	210	30	18	23	M16	4.32
512	14,480	55	110	255	70	28	38	70	105	135	210	32	18	23	M16	4.99
SN513	17,330	60	120	275	80	30	43	80	110	150	230	36	18	23	M16	5.64
514	-	-	125	275	80	30	44	80	115	155	230	36	18	23	M16	7.00
515	19,040	65	130	280	80	30	41	80	115	155	230	38	18	23	M16	6.19
516	25,420	70	140	315	90	32	43	95	120	175	260	40	22	27	M20	8.17
SN517	27,360	75	150	320	90	32	46	95	125	185	260	42	22	27	M20	9.37
518	31,580	80	160	345	100	35	62.4	100	145	195	290	50	22	27	M20	11.50
519	34,540	85	170	345	100	35	53	112	140	210	290	-	22	27	M20	13.50
520	42,640	90	180	380	110	40	70.3	112	160	218	320	54	26	32	M24	16.30
SN522	50,730	100	200	410	120	45	80	125	175	240	350	60	26	32	M24	25.10
524	57,910	110	215	410	120	45	86	140	185	270	350	64	26	32	M24	27.20
526	68,970	115	230	445	130	50	90	150	190	290	380	64	28	36	M24	35.20
528	79,000	125	250	500	150	50	98	150	205	305	420	70	33	42	M30	43.70
SN530	97,240	135	270	530	160	60	106	160	220	325	450	76	33	42	M30	45.30
532	119,700	140	290	550	160	60	114	170	235	345	470	80	33	42	M30	50.75
534	-	150	310	635	170	70	120	180	240	370	525	80	34	44	M30	73.60

SN600型

型番	価格(円)	d	D	B	b	G	F	A	L	H	E	X	U	V	S	重量(kg)
SN605	8,680	20	60	185	52	22	34	50	80	90	150	27	15	20	M12	2.11
606	9,010	25	72	185	52	22	37	50	82	95	150	27	15	20	M12	2.09
607	10,360	30	80	205	60	25	41	60	90	110	170	32	15	20	M12	3.40
608	11,210	35	90	205	60	25	43	60	95	115	170	34	15	20	M12	3.60
SN609	13,220	40	100	255	70	28	46	70	105	130	210	36	18	23	M16	5.30
610	14,480	45	110	255	70	30	50	70	115	135	210	39	18	23	M16	5.50
611	18,580	50	120	275	80	30	53	80	120	150	230	40	18	23	M16	6.90
612	19,150	55	130	280	80	30	56	80	125	155	230	44	18	23	M16	8.80
SN613	24,170	60	140	315	90	32	58	95	130	175	260	46	22	27	M20	9.80
614	-	-	150	320	90	32	61	95	130	185	260	46	22	27	M20	11.50
615	30,440	65	160	345	100	35	65	100	140	195	290	51	22	27	M20	13.00
616	35,570	70	170	345	100	35	68	112	145	212	290	52	22	27	M20	15.50
SN617	42,640	75	180	380	110	40	70	112	155	223	320	56	26	32	M24	16.30
618	46,400	80	190	380	110	40	74	112	160	230	320	58	26	32	M24	20.00
619	56,770	85	200	410	120	45	77	125	170	250	350	60	26	32	M24	28.00
620	67,930	90	215	410	120	45	83	140	175	270	350	64	26	32	M24	30.50
SN622	89,260	100	240	450	130	50	90	150	190	300	390	69	28	36	M24	42.00
624	134,660	110	260	530	160	60	96	160	205	320	450	73	33	42	M30	59.00
626	139,790	115	280	550	160	60	103	170	215	340	470	77	33	42	M30	61.50
628	171,860	125	300	610	170	65	112	180	235	365	520	83	35	45	M30	88.00
SN630	200,070	135	320	650	180	65	118	190	245	385	560	88	35	45	M30	89.00
632	242,390	140	340	680	190	70	124	200	255	405	580	93	42	50	M36	127.00

大口徑プランマー SN200型

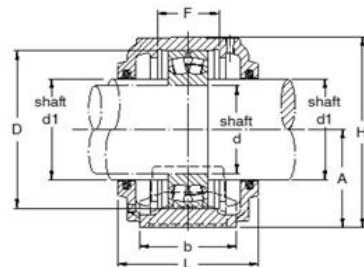
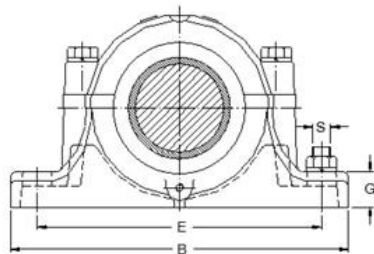

型番	価格(円)	シャフト径		D	B	b	G	F	A	L	H	E	S	Zシール d1	重量 (kg)	ENDカ バー
		d	d1													
SN205	14,000	25	30	52	165	46	22	25	40	67	75	130	M12	ZF7	1.4	EPS07
206	14,600	30	35	62	185	52	22	30	50	77	90	150	M12	ZF8	2.2	EPS08
207	17,000	35	45	72	185	52	22	33	50	82	95	150	M12	ZF10	2.5	EPS10
208	17,100	40	50	80	205	60	25	33	60	85	110	170	M12	ZF11	3.2	EPS11
SN209	18,200	45	55	85	205	60	25	31	60	85	112	170	M12	ZF12	3.0	EPS12
210	18,400	50	60	90	205	60	25	33	60	90	115	170	M12	ZF13	3.3	ESP13
211	24,590	55	65	100	255	70	28	33	70	95	130	210	M16	ZF15	4.8	EPS15
212	26,330	60	70	110	255	70	30	38	70	105	135	210	M16	ZF16	5.3	EPS16
SN213	27,210	65	75	120	275	80	30	43	80	110	150	230	M16	ZF17	6.5	EPS17
214	28,840	70	80	125	275	80	30	44	80	115	155	230	M16	ZF18	7.0	EPS18
215	29,720	75	85	130	280	80	30	41	80	115	155	230	M16	ZF19	7.0	EPS19
216	39,880	80	90	140	315	90	32	43	95	120	175	260	M20	ZF20	9.5	EPS20
SN217	41,190	85	95	150	320	90	32	46	95	125	185	260	M20	ZF21	10.5	EPS21
218	53,430	90	100	160	345	100	35	62.4	100	145	195	290	M20	ZF22	13.0	EPS22
219	64,890	95	110	170	345	100	35	53	112	140	210	290	M20	ZF24	15.5	EPS24
220	67,850	100	115	180	380	110	40	70.3	112	160	218	320	M24	ZF26	20.5	EPS26
SN222	82,760	110	125	200	410	120	45	80	125	175	240	350	M24	ZF28	26.2	EPS28
224	94,850	120	135	215	410	120	45	86	140	185	270	350	M24	ZF30	34.6	EPS30
226	112,860	130	145	230	445	130	50	90	150	190	290	380	M24	ZF33	41.8	EPS33
228	129,960	140	155	250	500	150	50	98	150	205	305	420	M30	ZF35	53.5	EPS35
SN230	196,080	150	165	270	530	160	60	106	160	220	325	450	M30	ZF37	58.2	EPS37
232	230,280	160	175	290	550	160	60	114	170	235	345	470	M30	ZF39	72.5	EPS39

SN300型

型番	価格(円)	シャフト径		D	B	b	G	F	A	L	H	E	S	Zシール d1	重量 (kg)	ENDカ バー
		d	d1													
SN305	18,830	25	30	60	185	52	22	34	50	80	90	1150	M12	ZF7	1.9	EPS07
306	19,500	30	35	72	185	52	22	37	50	82	95	150	M12	ZF8	2.2	EPS08
307	22,420	35	45	80	205	60	25	41	60	90	110	170	M12	ZF10	3.5	EPS10
308	22,870	40	50	90	205	60	25	43	60	95	115	170	M12	ZF11	3.4	EPS11
SN309	25,220	45	55	100	255	70	28	46	70	105	130	210	M16	ZF12	5.2	EPS12
310	28,140	50	60	110	255	70	30	50	70	115	135	210	M16	ZF13	5.3	EPS13
311	29,370	55	65	120	275	80	30	53	80	120	150	230	M16	ZF15	6.5	EPS15
312	31,690	60	70	130	280	80	30	56	80	125	155	230	M16	ZF16	8.0	EPS16
SN313	40,700	65	75	140	315	90	32	58	95	130	175	260	M20	ZF17	10.0	EPS17
314	48,220	70	80	150	320	90	32	61	95	130	185	260	M20	ZF18	11.0	EPS18
315	50,960	75	85	160	345	100	35	65	100	140	195	290	M20	ZF19	12.8	EPS19
316	58,710	80	90	170	345	100	35	68	112	145	212	290	M20	ZF20	15.0	EPS20
SN317	70,790	85	95	180	380	110	40	70	112	155	223	320	M24	ZF21	15.8	EPS21
318	76,840	90	100	190	380	110	40	74	112	160	230	320	M24	ZF22	19.4	EPS22
319	90,740	95	110	200	410	120	45	77	125	170	250	350	M24	ZF24	27.2	EPS24
320	103,850	100	115	215	410	120	45	83	140	175	270	350	M24	ZF26	28.9	EPS26
SN322	126,540	110	125	240	450	130	50	90	150	190	300	390	M24	ZF28	40.2	EPS28
324	173,380	120	135	260	530	160	60	96	160	205	320	450	M30	ZF30	56.5	EPS30
326	179,310	130	150	280	550	160	60	103	170	215	340	470	M30	ZF34	65.5	EPS34
328	211,380	140	160	300	610	170	65	112	180	235	365	520	M30	ZF36	73.5	EPS36
SN330	252,940	150	170	320	650	180	65	118	190	245	385	560	M30	ZF38	80.2	EPS38
332	315,880	160	180	340	680	190	70	124	200	255	405	580	M36	ZF40	105.4	EPS40

異口径プランマー SNZ200型

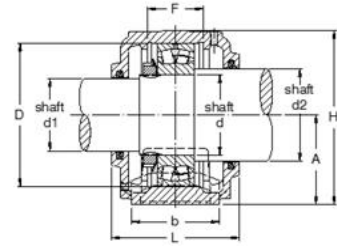
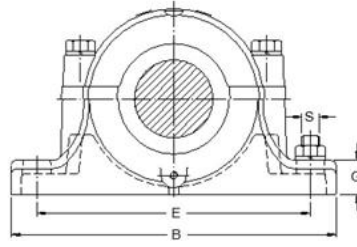

型番	価格(円)	シャフト径			D	B	b	G	F	A	L	H	E	S	Zシール		ENDカバー
		d	d1	d2											d1	d2	
SNZ205	14,000	25	20	30	52	165	46	22	25	40	67	75	130	M12	ZF5	ZF7	EPS05
206	14,600	30	25	35	62	185	52	22	30	50	77	90	150	M12	ZF6	ZF8	EPS06
207	16,700	35	30	45	72	185	52	22	33	50	82	95	150	M12	ZF7	ZF10	EPS07
208	17,100	40	35	50	80	205	60	25	33	60	85	110	170	M12	ZF8	ZF11	EPS08
SNZ209	18,200	45	40	55	85	205	60	25	31	60	85	112	170	M12	ZF9	ZF12	EPS09
210	18,400	50	45	60	90	205	60	25	33	60	90	115	210	M12	ZF10	ZF13	EPS10
211	25,220	55	50	65	100	255	70	28	33	70	95	130	210	M16	ZF11	ZF15	EPS11
212	27,020	60	55	70	110	255	70	30	38	70	105	135	230	M16	ZF12	ZF16	EPS12
SNZ213	27,910	65	60	75	120	275	80	30	43	80	110	150	230	M16	ZF13	ZF17	EPS13
214	29,590	70	60	80	125	275	80	30	44	80	115	155	230	M16	ZF13	ZF18	EPS13
215	30,500	75	65	85	130	280	80	30	41	80	115	155	260	M16	ZF15	ZF19	EPS15
216	40,920	80	70	90	140	315	90	32	43	95	120	175	260	M20	ZF16	ZF20	EPS16
SNZ217	42,270	85	75	95	150	320	90	32	46	95	125	185	290	M20	ZF17	ZF21	EPS17
218	54,820	90	80	100	160	345	100	35	62.4	100	145	195	290	M20	ZF18	ZF22	EPS18
219	66,700	95	85	110	170	345	100	35	53	112	140	210	320	M20	ZF19	ZF24	EPS19
220	69,620	100	90	115	180	380	110	40	70.3	112	160	218	350	M24	ZF20	ZF26	EPS20
SNZ222	82,760	110	100	125	200	410	120	45	80	125	175	240	350	M24	ZF22	ZF28	EPS22
224	94,850	120	110	135	215	410	120	45	86	140	185	270	350	M24	ZF24	ZF30	EPS24
226	112,860	130	115	145	230	445	130	50	90	150	190	290	380	M24	ZF26	ZF33	EPS26
228	129,960	140	125	155	250	500	150	50	98	150	205	305	420	M30	ZF28	ZF35	EPS28
SNZ230	196,080	150	135	165	270	530	160	60	106	160	220	325	450	M30	ZF30	ZF37	EPS30
232	230,280	160	140	175	290	550	160	60	114	170	235	345	470	M30	ZF32	ZF39	EPS32

SNZ300型

型番	価格(円)	シャフト径			D	B	b	G	F	A	L	H	E	S	Zシール		ENDカバー
		d	d1	d2											d1	d2	
SNZ305	18,350	25	20	30	60	185	52	22	34	50	80	90	150	M12	ZF5	ZF7	EPS05
306	19,010	30	25	35	72	185	52	22	37	50	82	95	150	M12	ZF6	ZF8	EPS06
307	21,850	35	30	45	80	205	60	25	41	60	90	110	170	M12	ZF7	ZF10	EPS07
308	22,290	40	35	50	90	205	60	25	43	60	95	115	170	M12	ZF8	ZF11	EPS08
SNZ309	25,650	45	40	55	100	255	70	28	46	70	105	130	210	M16	ZF9	ZF12	EPS09
310	28,610	50	45	60	110	255	70	30	50	70	115	135	210	M16	ZF10	ZF13	EPS10
311	29,870	55	50	65	120	275	80	30	53	80	120	150	230	M16	ZF11	ZF15	EPS11
312	31,690	60	55	70	130	280	80	30	56	80	125	155	230	M16	ZF12	ZF16	EPS12
SNZ313	40,700	65	60	75	140	315	90	32	58	95	130	175	260	M20	ZF13	ZF17	EPS13
314	48,220	70	60	80	150	320	90	32	61	95	130	185	260	M20	ZF13	ZF18	EPS13
315	50,960	75	65	85	160	345	100	35	65	100	140	195	290	M20	ZF15	ZF19	EPS15
316	58,710	80	70	90	170	345	100	35	68	112	145	212	290	M20	ZF16	ZF20	EPS16
SNZ317	70,790	85	75	95	180	380	110	40	70	112	155	223	320	M24	ZF17	ZF21	EPS17
318	76,840	90	80	100	190	380	110	40	74	112	160	230	320	M24	ZF18	ZF22	EPS18
319	90,740	95	85	110	200	410	120	45	77	125	170	250	350	M24	ZF19	ZF24	EPS19
320	103,850	100	90	115	215	410	120	45	83	140	175	270	350	M24	ZF20	ZF26	EPS20
SNZ322	126,540	110	100	125	240	450	130	50	90	150	190	300	390	M24	ZF22	ZF28	EPS22
324	166,440	120	110	135	260	530	160	60	96	160	205	320	450	M30	ZF24	ZF30	EPS24
326	172,140	130	115	150	280	550	160	60	103	170	215	340	470	M30	ZF26	ZF34	EPS26
328	202,920	140	125	160	300	610	170	65	112	180	235	365	520	M30	ZF28	ZF36	EPS28
SNZ330	242,820	150	135	170	320	650	180	65	118	190	245	385	560	M30	ZF30	ZF38	EPS30
332	303,240	160	140	180	340	680	190	70	124	200	255	405	580	M36	ZF32	ZF40	EPS32

SN3000型

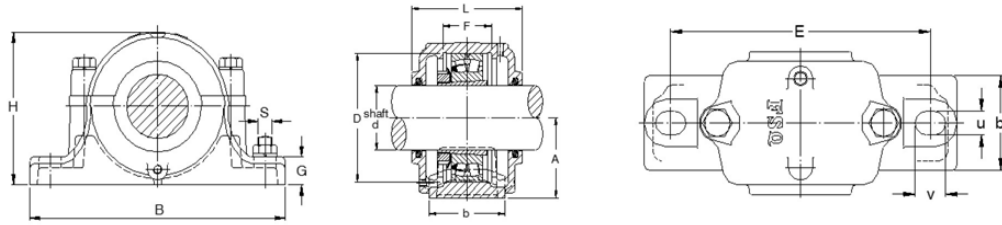

型番	価格(円)	d	D	B	b	G	F	A	L	H	E	U	V	t
SN3024	56,090	110	180	380	110	40	56	112	150	217	320	26	35	M20
3026	65,780	115	200	410	120	45	62	125	160	240	350	26	35	M20
3028	75,580	125	210	410	120	45	63	140	170	260	350	26	35	M20
3030	94,960	135	225	445	130	50	66	150	175	283	380	28	38	M24
SN3032	105,910	140	240	460	130	50	70	150	190	290	390	28	38	M24
3034	132,240	150	260	530	160	60	77	160	200	310	450	33	42	M24
3036	149,340	160	280	550	160	60	84	170	210	330	470	33	42	M24
3038	158,460	170	290	550	160	60	85	170	210	335	470	33	42	M24
SN3040	240,540	180	310	610	170	60	92	180	235	355	515	33	42	M24
3044	313,500	200	340	690	190	70	100	200	255	405	580	40	52	M30
3048	363,660	220	360	720	190	75	102	210	265	420	680	40	52	M30
3052	445,740	240	400	820	200	80	114	240	285	472	780	48	70	M30

SN3100型

型番	価格(円)	d	D	B	b	G	F	A	L	H	E	U	V	t
SN3122	58,480	100	180	380	110	40	66	112	155	217	320	26	35	M20
3124	68,290	110	200	410	120	45	72	125	165	240	350	26	35	M20
3126	76,840	115	210	410	120	45	74	140	170	260	350	26	35	M20
3128	99,860	125	225	445	130	50	78	150	180	283	380	28	38	M24
SN3130	112,860	135	250	500	150	50	90	150	200	295	420	33	42	M24
3132	139,080	140	270	530	160	60	96	160	215	315	450	33	42	M24
3134	158,460	150	280	550	160	60	98	170	220	330	470	33	42	M24
3136	220,020	160	300	610	170	70	106	180	230	355	520	33	42	M30
SN3138	267,900	170	320	650	180	70	114	190	240	375	560	33	42	M30

SD500型

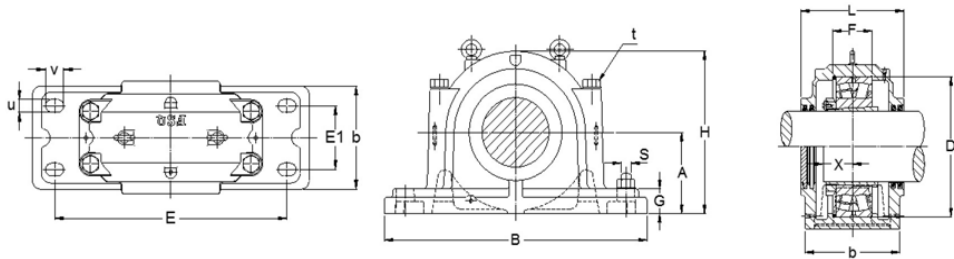

型番	価格(円)	d	D	A	B	E	b	G	F	H	L	E1	U	V	ガイドリング
SD534	220,020	150	310	180	620	510	230	60	96	360	270	140	35	52.00	SR310X10
536	233,700	160	320	190	650	540	240	60	96	380	280	150	35	52.00	SR320X10
538	304,380	170	340	200	700	570	260	65	102	400	290	160	35	55.00	SR340X10
540	365,940	180	360	210	740	610	270	65	108	420	300	170	35	55.00	SR360X10
SD544	438,900	200	400	240	820	680	300	70	118	475	330	190	42	62.00	SR400X10
548	563,160	220	440	260	880	740	310	85	130	515	340	200	42	62.00	SR440X10
552	702,240	240	480	280	940	790	340	85	140	560	370	210	42	62.00	SR480X10
556	973,560	260	500	300	990	830	370	100	140	590	390	230	50	70.00	SR500X10
SD560	1,197,000	280	540	325	1060	890	390	100	150	640	410	250	50	70.00	SR540X10
564	見積	300	580	355	1110	930	420	110	160	690	440	270	57	77.00	SR580X10

SD600型

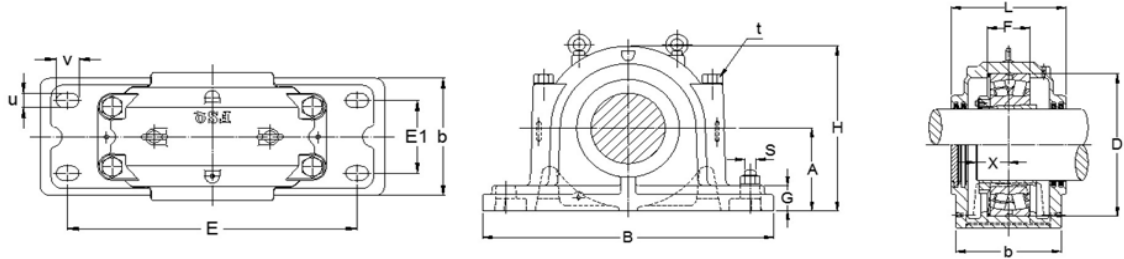

型番	価格(円)	d	D	A	B	E	b	G	F	H	L	E1	U	V	ガイドリング	数
SD634	389,880	150	360	210	740	610	270	65	130	420	300	170	35	55	SR360X10	1
636	426,360	160	380	225	780	640	290	70	136	450	320	180	40	60	SR380X10	1
638	523,260	170	400	240	820	680	300	70	142	475	330	190	40	60	SR400X10	1
640	657,780	180	420	250	860	710	320	85	148	500	350	200	42	62	SR420X10	1
SD644	730,740	200	460	280	920	770	330	85	155	550	360	210	42	62	SR460X10	1
648	1,059,060	220	500	300	990	830	370	100	165	590	390	230	50	70	SR500X10	1
652	1,345,200	240	540	325	1060	890	390	100	175	640	410	250	50	70	SR540X10	1
656	1,584,600	260	580	355	1110	930	420	110	185	690	440	270	57	77	SR580X10	1

SN3000型

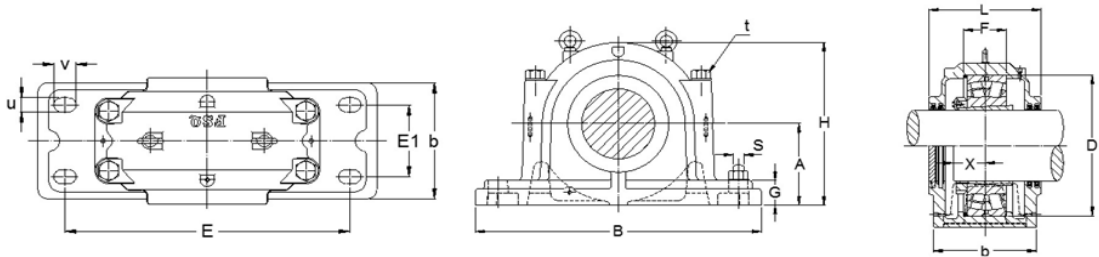

型番	価格(円)	d	D	A	B	E	b	G	F	H	L	E1	U	V	ガイドリング	数
SD3034	188,100	150	260	160	540	450	200	50	77	320	230	110	35	52	SR260X10	1
3036	207,480	160	280	170	560	470	220	50	84	340	250	120	35	52	SR280X10	1
3038	225,720	170	290	170	560	470	220	50	85	345	250	120	35	52	SR290X10	1
3040	232,560	180	310	180	620	510	230	60	92	360	270	140	35	55	SR310X10	1
SD3044	326,040	200	340	200	700	570	260	65	100	400	290	160	35	55	SR340X10	1
3048	378,480	220	360	210	740	610	270	65	102	420	300	170	35	55	SR360X10	1
3052	458,280	240	400	240	820	680	300	70	114	475	330	190	42	62	SR400X10	1
3056	572,280	260	420	250	860	710	320	85	116	500	350	200	42	62	SR420X10	1
SD3060	694,260	280	460	280	920	770	330	85	128	550	360	210	42	62	SR460X10	1
3064	815,100	300	480	280	940	790	340	85	131	560	370	210	42	62	SR480X10	1
3068	1,069,320	320	520	310	1020	860	370	100	143	615	400	230	50	70	SR520X10	1
3072	見積	340	540	325	1060	890	390	100	144	640	410	250	50	70	SR540X10	1
3076	見積	360	560	340	1080	900	390	100	145	665	410	260	50	70	SR560X10	1

エンドカバー EPS型

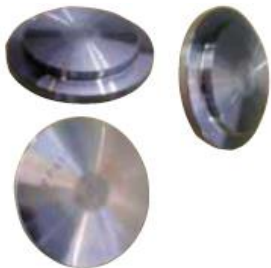

型番	価格(円)
EPS05	2,670
06	2,780
07	3,010
08	3,140
EPS09	3,260
10	3,380
11	3,760
12	4,140
EPS13	4,510
14	4,640
15	4,970

型番	価格(円)
EPS16	5,430
17	5,560
18	6,300
19	8,560
EPS20	9,330
22	10,330
24	11,410
26	11,410
EPS28	14,610
30	16,150
32	16,990

型番	価格(円)
EPS34	22,570
36	25,080
38	31,250
40	32,450
EPS44	42,070
48	54,080
52	64,890
56	78,120
EPS60	見積
64	見積
68	見積

SD3100型

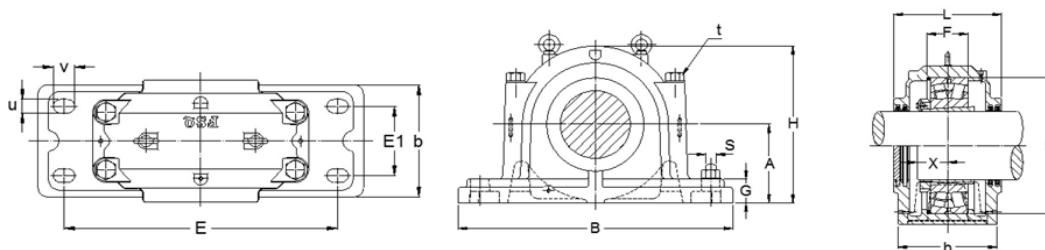

型番	価格(円)	d	D	A	B	E	b	G	F	H	L	E1	U	V	ガイドリング	数
SD3134	250,800	150	280	170	560	470	220	50	98	340	250	120	35	42	SR250X10	1
3136	275,880	160	300	180	630	520	250	55	106	365	270	140	35	52	SR300X10	1
3138	300,960	170	320	190	680	560	270	55	114	385	310	140	35	55	SR320X10	1
3140	326,040	180	340	200	70	570	260	65	122	400	290	160	35	55	SR340X10	1
SD3144	401,280	200	370	225	780	640	290	70	130	450	320	180	40	60	SR370X10	1
3148	463,980	220	40	240	820	680	300	70	138	475	330	190	42	62	SR400X10	1
3152	677,160	240	440	260	880	740	310	85	154	515	340	200	42	62	SR440X10	1
3156	802,560	260	460	280	920	770	330	85	156	550	360	210	42	62	SR460X10	1
SD3160	890,340	280	500	300	990	830	370	100	170	590	390	230	50	70	SR500X10	1
3164	1,103,520	300	540	325	1060	890	390	100	186	640	410	250	50	70	SR540X10	1
3168	見積	320	580	355	1110	930	420	110	200	690	440	270	57	77	SR280X10	1
3172	見積	340	600	365	1140	960	46	120	202	710	470	310	57	77	SR600X10	1
SD3176	見積	360	620	375	1160	980	490	120	204	735	500	320	57	77	SR620X10	1
3180	見積	380	650	390	1220	1040	510	125	210	765	520	340	57	77	SR650X10	1

FSQ



We Bear The Rolling World

CSD32-500



SD556



SOFN226



SSDS231-710

Weight 2,950kg
length 1,900mm



SD3152

ガイドリング価格表と組み合わせ表

型番構成

SR 52 X 5

外径 幅

型番	価格(円)	外径	幅	適用プランマ	ベアリング	アダプタ	数	
SR52X5	1,250	52	5	SN505	1205K	H205	2	
				SN205/SNZ205	1205	AN05/AW05	2	
SR52X7	1,250	7	7	SN505	2205K/22205K	H305	1	
				SB205/NXZ205	2205/22205	AN05/AW05	1	
SR62X7	1,380	62	7	SN506	1206K	H206	2	
				SN206/SNZ206	1206	AN06/AW06	2	
SR62X8.5	1,380		8.5	8.5	SN605	1305K	H305	2
					SN305/SNZ305	1305	AN05/AW05	2
SR62X10	1,380	10	10	SN506	2206K/22205K	H306	1	
				SN605	2305K	H2305	1	
				SN206/SNZ206	2206/22206	AN06/AW06	1	
SR72X8	1,460	72	8	SN507	1207K	H207	2	
				SN207/SNZ207	1207	AN07/AW07	2	
SR72X9	1,500		9	9	SN606	1306K	H306	2
					SN306/SNZ306	1306	AN06/AW06	2
SR72X10	1,500		10	10	SN507	2207K/22207K	H307	1
					SN606	2306K	H2306	1
		SN207/SNZ207			2207/22207	AN07/AW07	1	
		SN306/SNZ306	2306	AN06/AW06	1			
SR80X7.5	1,540	80	7.5	SN508	1208K	H208	2	
				SN208/SNZ208	1208	AN08/AW08	2	
SR80X10	1,630		10	10	SN507	2208K/22208K	H308	1
					SN607	1307K	H307	2
					SN607	2307K	H2307	1
					SN208/SNZ208	2208/22208	AN08/AW08	1
		SN307/SNZ307	1307	AN07/AW07	2			
		SN307/SNZ307	2307	AN07/AW07	1			
SR85X6	1,630	85	6	SN509	1209K	H209	2	
				SN209/SNZ209	1209	AN09/AW09	2	
SR85X8	1,700	8	8	SN509	2209K/22209K	H309	1	
				SN209/SNZ209	2209/22209	AN09/AW09	1	
SR90X6.5	1,830	90	6.5	SN510	1210K	H210	2	
				SN210/SNZ210	1210	AN10/AW10	2	
SR90X10	1,950		10	10	SN510	2210K/22210K	H310	1
					SN608	1308K/21308K	H308	2
					SN608	2308K/22308K	H2308	1
					SN210/SNZ210	2210/22210	AN10/AW10	1
		SN308/SNZ308	1308/21308	AN08/AW08	2			
		SN308/SNZ308	2308/22308	AN08/AW08	1			
SR100X6	2,130	100	6	SN511	1211K	H211	2	
				SN211/SNZ211	1211	AN11/AW11	2	
SR100X8	2,200		8	8	SN511	2211K/22211K	H311	1
					SN211/SNZ211	2211/22211	AN11/AW11	1
SR100X10	2,260		10	10	SN609	2309K/22309K	H2309	1
					SN309/SNZ309	2309/22309	AN09/AW09	1
SR100X10.5	2,260	10.5	10.5	SN609	1309K/21309K	H309	2	
				SN309/SNZ309	1309/21309	AN09/AW09	2	
SR110X8	2,260	110	8	SN512	1212K	H212	2	
				SN212/SNZ212	1212	AN12/AW12	2	
SR110X10	2,330		10	10	SN512	2212K/22212K	H312	1
					SN610	2310K/22310K	H2310	1
					SN212/SNZ212	2212/22212	AN12/AW12	1
			SN310/SNZ310	2310/22310	AN10/AW10	1		
SR110X11.5	2,380	11.5	11.5	SN610	1310K/21310K	H310	2	
				SN310/SNZ310	1310/21310	AN10/AW10	2	
SR120X10	2,630	120	10	SN513	1213K	H213	2	
				SN611	2311K/22311K	H2311	1	
				SN213/SNZ213	1213	AN13/AW13	2	
				SN311/SNZ311	2311/22311	AN11/AW11	1	
SR120X12	2,720	12	12	SN513	2213K/22213K	H313	1	
				SN611	1311K/21311K	H311	2	
				SN213/SNZ213	2213/22213	AN13/AW13	1	
		SN311/SNZ311	1311/21311	AN11/AW11	2			
SR125X10	3,010	125	10	SN214/SNZ214	1214	AN14/AW14	2	
SR125X13	3,140			13	SN214/SNZ214	2214/22214	AN14/AW14	1

ガイドリング価格表と組み合わせ表

型番構成

SR 52 X 5

外径 幅

型番	価格(円)	外径	幅	適用プランマ	ベアリング	アダプタ	数	
SR130X8	2,950	130	8	SN515 SN215/SNZ215	1215K 1215	H215 AN15/AW15	2 2	
SR130X10	3,010		10	SN515 SN612 SN215/SNZ215 SN312/SNZ312	2215K/22215K 2312K/22312K 2215/22215 2312/22312	H315 H2312 AN15/AW15 AN12/AW12	1 1 1 1	
SR130X12.5	3,140		12.5	SN612 SN312/SNZ312	1312K/21312K 1312/21312	H312 AN12/AW12	2 2	
SR140X8.5	3,260		140	8.5	SN516 SN216/SNZ216	1216K 1216	H216 AN16/AW16	2 2
SR140X10	3,260			10	SN516 SN613 SN216/SNZ216 SN313/SNZ313	2216K/22216K 2313K/22313K 2216/22216 2313/22313	H316 H2313 AN16/AW16 AN13/AW13	1 1 1 1
SR140X12.5	3,380			12.5	SN613 SN313/SNZ313	1313K/21313K 1313/21313	H313 AN13/AW13	2 2
SR150X9	3,520	150		9	SN517 SN217/SNZ217	1217K 1217	H217 AN17/AW17	2 2
SR150X10	3,520			10	SN517 SN217/SNZ217 SN314/SNZ314	2217K/22217K 2217/22217 22314	H317 AN17/AW17 AN14/AW14	1 1 1
SR150X13	4,250			13	SN314/SNZ314	1314/21314	AN14/AW14	2
SR160X10	4,250		160	10	SN518 SN615 SN218/SNZ218 SN315/SNZ315	23218K 2315K/22315K 23218 2315/22315	H2318 H2315 AN18/AW18 AN15/AW15	1 1 1 1
SR160X11.2	4,250			11.2	SN518 SN218/SNZ218	2218K/22218K 2218/22218	H318 AN18/AW18	2 2
SR160X14	4,610			14	SN615 SN315/SNZ315	1315K/21315K 1315/21315	H315 AN15/AW15	2 2
SR160X16.2	5,220	16.2		SN518 SN218/SNZ218	1218K 1218	H218 AN18/AW18	2 2	
SR170X10	4,480	170		10	SN519 SN616 SN219/SNZ219 SN316/SNZ316	22219K 2316K/22316K 2219/22219 2316/22316	H319 H2316 AN19/AW19 AN16/AW16	1 1 1 1
SR170X10.5	4,550			10.5	SN519 SN219/SNZ219	1219K 1219	H219 AN19/AW19	2 2
SR170X14.5	5,020		14.5	SN616 SN316/SNZ316	1316K/21316K 1316/21316	H316 AN16/AW16	2 2	
SR180X10	5,020		180	10	SN520 SN617 SN220/SNZ220 SN317/SNZ317 SN3024 SN3122	23220K 2317K/22317K 23220 2317/22317 23024K 23122K	H2320 H2317 AN20/AW20 AN17/AW17 H3024 H3122	1 1 1 1 1 1
SR180X12.1	5,520			12.1	SN520 SN220/SNZ220	2220K/22220K 2220/22220	H320 AN20/AW20	2 2
SR180X14.5	5,640			14.5	SN617 SN317/SNZ317	1317K/21317K 1317/21317	H317 AN17/AW17	2 2
SR190X10	5,520	190		10	SN618 SN318/SNZ318	2318K/22318K 2318/22318	H2318 AN18/AW18	1 1
SR190X15.5	7,400			15.5	SN618 SN318/SNZ318	1318K 1318/21318	H318 AN18/AW18	2 2
SR200X10	5,890			200	10	SN522 SN619 SN222/SNZ222 SN319/SNZ319 SN3026 SN3124	23222K 2319K/22319K 23222 2319/22319 23026K 23124K	H2322 H2319 AN22/AW22 AN19/AW19 H3026 H3124
SR200X13.5	7,140		13.5		SN522 SN222/SNZ222	2222K/22222K 2222/22222	H322 AN22/AW22	2 2
SR200X16	8,900		16		SN619 SN319/SNZ319	1319K 1319/21319	H319 AN19/AW19	2 2
SR210X10	6,650		210		10	SN3028 SN3126	23028K 23126K	H3028 H3126

ガイドリング価格表と組み合わせ表

型番構成

SR 52 X 5

外径 幅

型番	価格(円)	外径	幅	適用プランマ	ベアリング	アダプタ	数
SR215X10	6,770	215	10	SN524	23224K	H2324	1
				SN620	2320K/22320K	H2320	1
				SN224/SNZ224	23224	AN24/AW24	1
				SN320/SNZ320	2320/22320	AN20/AW20	1
SR215X14	7,770	215	14	SN214	22224K	H3124	2
				SN224/SNZ224	22224	AN24/AW24	2
SR215X18	11,080	215	18	SN620	1320K	H320	2
				SN320/SNZ320	1320/21320	AN20/AW20	2
SR225X10	7,820	225	10	SN3030	23030K	H3030	1
SR230X10	7,820	230	10	SN3128	23128K	H3128	1
				SN526	23226K	H2326	1
SR230X13	9,200	230	13	SN226/SNZ226	23226	AN26/AW26	1
				SN526	22226K	H3126	2
SR240X10	9,200	240	10	SN226/SNZ226	22226	AN26/AW26	2
				SN622	2322K/22322K	H2322	1
SR240X20	12,960	240	20	SN322/SNZ322	22322	AN22/AW22	1
				SN3032	23032K	H3032	1
SR250X10	10,550	250	10	SN622	1322K	H322	2
				SN322/SNZ322	21322	AN22/AW22	2
SR250X15	12,120	250	15	SN528	23228K	H2328	1
				SN228/SNZ228	23228	AN28/AW28	1
SR260X10	11,180	260	10	SN3130	23130K	H3130	1
				SN528	22228K	H3128	2
SR270X10	12,440	270	10	SN228/SNZ228	22228	AN28/AW28	2
				SN624	22324K	H2324	1
SR270X16.5	13,790	270	16.5	SN324/SNZ324	22324	AN24/AW24	1
				SN3034	23034K	H3034	1
SR280X10	13,170	280	10	S D 3034	23034K	H3034	1
				SN530	23230K	H2330	1
SR290X10	18,390	290	10	SN230/SNZ230	23230	AN30/AW30	1
				SN3132	23132K	H3132	1
SR290X17	21,420	290	17	SN530	22230K	H3130	2
				SN230/SNZ230	22230	AN30/AW30	2
SR300X10	19,540	300	10	SN626	22326K	H2326	1
				SN326/SNZ326	22326	AN26/AW26	1
SR310X10	21,270	310	10	SN3036	23036K	H3036	1
				SN3134	23134K	H3134	1
SR320X10	21,820	320	10	SD3036	23036K	H3036	1
				SN532	23232K	H2332	1
SR340X10	23,260	340	10	SN232/SNZ232	23232	AN32/AW32	1
				SN3038	23038K	H3038	1
SR360X10	27,590	360	10	SD3038	23038K	H3138	1
				SN532	22232K	H3132	2
SR380X10	33,340	380	10	SN232/SNZ232	22232	AN32/AW32	2
				SN628	22328K	H2328	1
SR300X10	19,540	300	10	SN328/SNZ328	22328	AN28/AW28	1
				SN3136	23136K	H3136	1
SR310X10	21,270	310	10	SN534	23234K	H2334	1
				SN3040	23040K	H3040	1
SR320X10	21,820	320	10	SD534	22234K	H3134	1
				SD3040	23040K	H3040	1
SR340X10	23,260	340	10	SN630	22330K	H2330	1
				SN330/SNZ330	22330	AN30/AW30	1
SR360X10	27,590	360	10	SN3138	23138K	H3138	1
				SD536	22236K	H3136	1
SR380X10	33,340	380	10	SN632	22332K	H2332	1
				SN332/SNZ332	22332	AN32/AW32	1
SR300X10	19,540	300	10	SN3044	23044K	H3044	1
				SD538	22238K	H3138	1
SR360X10	27,590	360	10	SD3044	23044K	H3044	1
				SD540	22240K	H3140	1
SR380X10	33,340	380	10	SD634	22334K	H2334	1
				SD3048	23048K	H3048	1
SR380X10	33,340	380	10	SD636	22336K	H2336	1

ガイドリング価格表と組み合わせ表

型番構成

SR 52 X 5

外径 幅

型番	価格(円)	外径	幅	適用プランマ	ベアリング	アダプタ	数
SR400X10	40,230	400	10	SD544	22244K	H3144	1
				SD638	22338K	H2338	1
				SD3052	23052K	H3052	1
SR420X10	41,380	420	10	SD640	22340K	H2340	1
				SD3056	23056K	H3056	1
SR440X10	42,530	440	10	SD548	22248K	H3148	1
SR460X10	44,830	460	10	SD644	22344K	H2344	1
				SD3060	23060K	H3060	1
SR480X10	45,980	480	10	SD552	22252K	H3152	1
				SD3064	23064K	H3064	1
SR500X10	48,280	500	10	SD556	22256K	H3156	1
				SD648	22348K	H2348	1
SR520X10	49,430	520	10	SD3068	23068K	H3068	1
SR540X10	71,270	540	10	SD560	22260K	H3160	1
				SD652	22352K	H2352	1
				SD3072	23072K	H3072	1
SR560X10	78,170	560	10	SD3076	23076K	H3076	1
SR580X10	85,060	580	10	SD564	22264K	H3164	1
				SD656	22356K	H2356	1

FSQ



We Bear The Rolling World

株式会社 誠和商会

〒542-8577 大阪市中央区安堂寺町1-5-6
TEL:06-6762-6301 FAX:06-6762-6300